

Understructure

The Uplift allows you to move your platforms up and down with no manual labor or lifting. This revolutionary platform is a scissor support system with integrated platform that is raised and lowered with an electric drill, allowing you and your team to setup your venue quickly, efficiently, and with the least amount of effort. Most importantly, the Uplift can be designed to stop at any number of points. The Uplift can be built into custom shapes and sizes to meet the needs of your venue, eliminating any storage requirements or hours of assembly time for setup and take down. This product is compatible with all Sightline Commercial Solutions' standard accessories, such as skirting, closure panels, and guardrails.



Understructure

Durability, Strength & Efficiency

No lifting needed - the Uplift is drill powered. Simply insert a recommended electric drill, with the provided adapter, into the gear box input shaft, and allow the drill to raise and lower the platform.

Aluminum frame construction is designed for maximum strength and long-term durability.

Anchored to floors with simple mechanical expansion anchors.

The Uplift is designed to stop at any level, allowing for the utmost customization.

Simple and consistently easy to operate. Raise and lower platform using a recommended drill. (See Operation Note for options.)

Delrin® wheels allow for smooth operation and are built to last. Smooth transition in around one minute

Able to lock to adjacent Uplifts to provide a flat, uniform surface or standalone as an independent system.



Technical Specifications

Standard Sizes:

3' x 8' (0.92 m x 2.44 m)

4' x 8' (1.22 m x 2.44 m)

Custom sizes and shapes available

Uniform live load: 150 psf.

Span: 12' max

Deflection: L/360

Frame material: Extruded 6005A-T61
Aluminum custom shapes

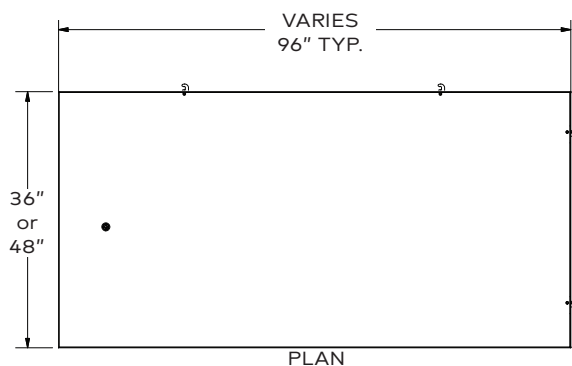

Operation Note

Recommended purchasing drill options for smooth operation of this product:

- Hilti SFC 22-A Electric Drill
- DeWalt 20V Max XR Lithium Ion Brushless Premium 3-Speed Drill/Driver Kit

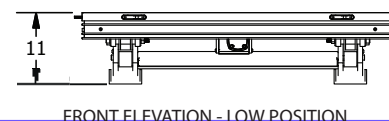
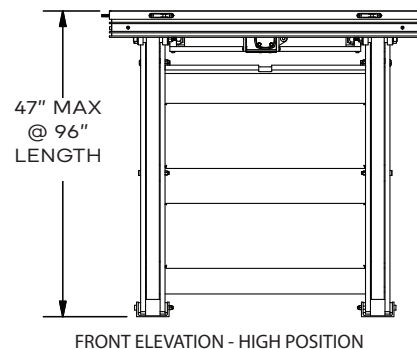

*The Uplift was designed for permanent installation only.